

Adding a New Tool for Servo Press (DPS-202R5A-20FB-X)

DATE: January 23th, 2018

- Operating with controller MFC-S120S (used by standard F type tools for 30-150 kN)
- Reducing tool weight by 50%
- Industry's smallest tool width 168 mm

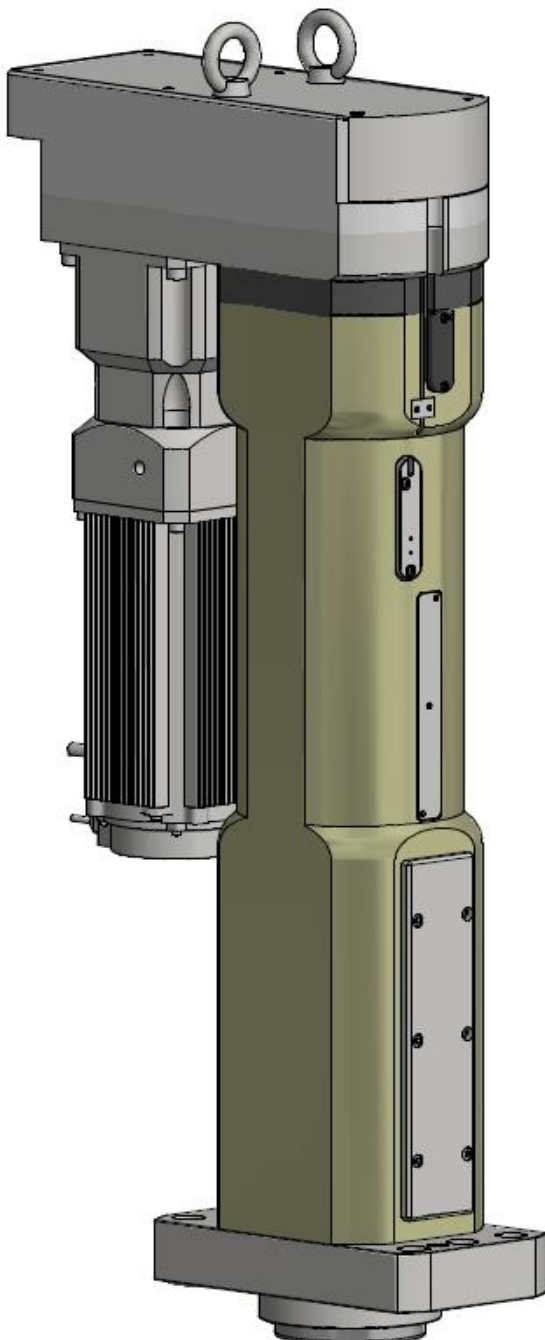

DPS-202R5A-20FB-X

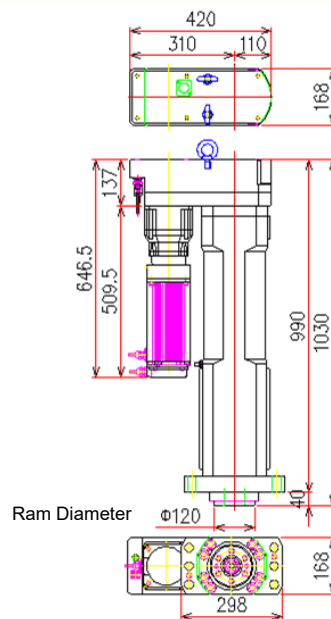

Specification	
Model	DPS-202R5A-20FB-X
Max. Load	200 kN
Load of Continuous Rating	65 kN
Max. Speed	53 mm/sec
Stroke	200 mm
Weight	218 kgf
Load Accuracy	$3\sigma/X \leq 1.5\%$
Distance Accuracy	Max. ± 0.01 mm
Maximum Rotating Play of Ram	0.11 deg.
Sensor Output	NPN

*Model for PNP: DPS-202R5A-20FB-PX

System Configuration

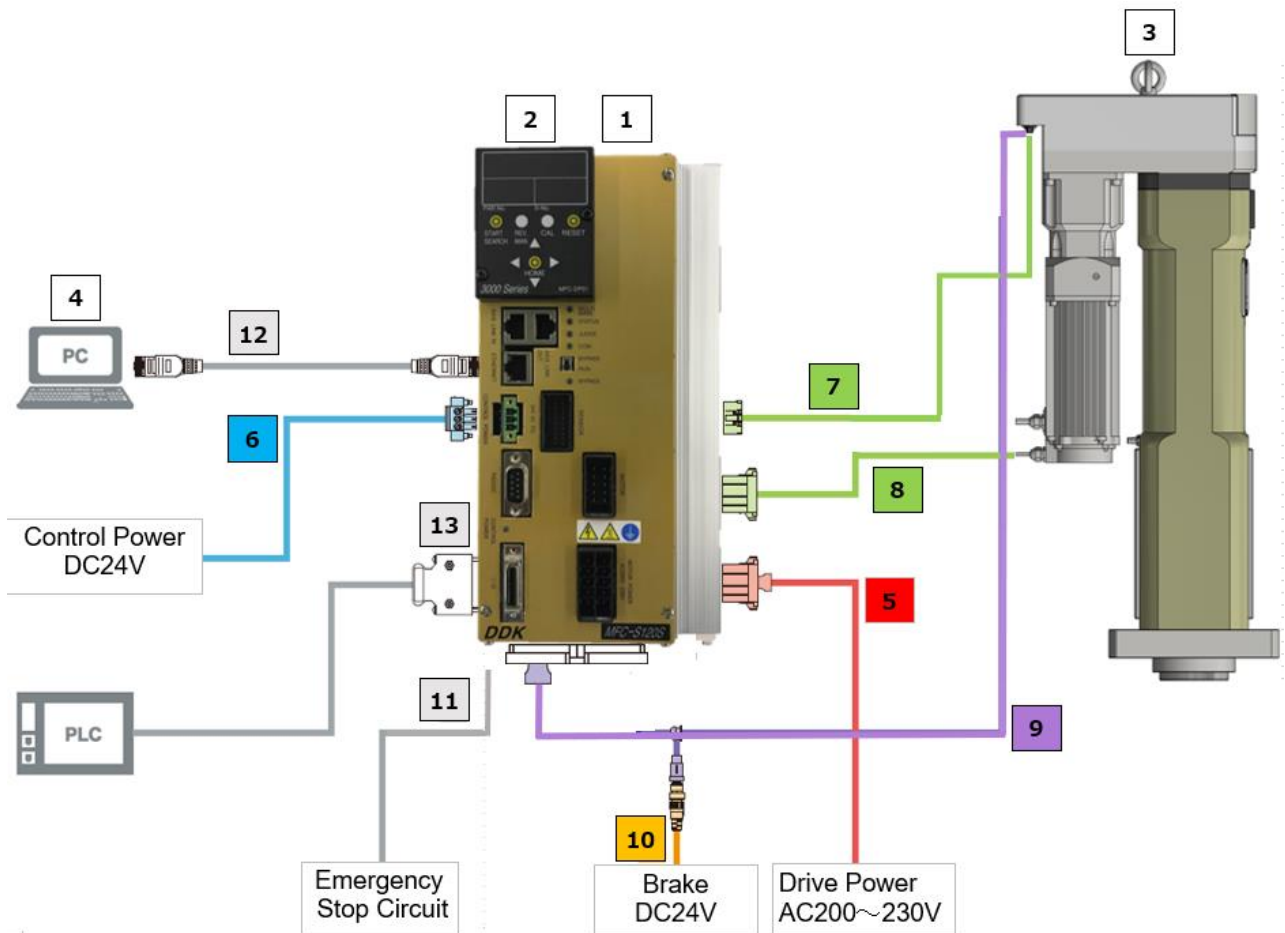

No	Name	Model	No	Name	Model
1	Controller (DSP3000)	MFC-S120S	8	Motor Cable for RM5 ^{*1}	C15-M1-M *
2	Display	MFC-DP01	9	Limit Sensor & Brake Cable ^{*1}	C30-L3-M *
3	Tool	DPS-202R5A-20FB-X	10	Brake Cable	C15-B3-M1-U
4	PC Software for DSP3000 (UC)	DSP-UC-N	11	Stop Signal Cable ^{*1}	C30-XA1-M *
5	Drive Power Cable ^{*1}	C15-D2-M *	12	ETHERNET Crossover ^{*1}	C30-UL1-M *
6	Control power Cable ^{*1}	C30-DC1-M *	13	Standard I/O Cable ^{*1}	C30-SU1-M *
7	Preamplifier & Resolver Cable for RM5 ^{*1}	C30-PR5-M *			

^{*1} Ask about cable length.



ELECTRICAL ASSEMBLY TOOLS
DAI-ICHI DENTSU LTD.

NUTRUNNER / HAND-HELD TOOL / SERVO PRESS

Headquarters

1-54-1, Shimoishihara, Chofu-City, Tokyo 182-0034 Japan
TEL: +81-424-40-1465 FAX: +81-424-40-1436
URL: <http://www.daiichi-dentsu.co.jp>
E-mail: sales@daiichi-dentsu.co.jp

Kani Plant

690-1 Omori, Kani-City, Gifu, 509-0238 Japan
TEL: +81-574-62-5865 FAX: +81-574-62-3523

